

(12) UK Patent Application (19) GB (11) 2 297 007 (13) A

(43) Date of A Publication 17.07.1996

(21) Application No 9525323.3
(22) Date of Filing 12.12.1995
(30) Priority Data
(31) 372780 (32) 13.01.1995 (33) US
417914 06.04.1995
485310 07.06.1995
515813 16.08.1995
538897 04.10.1995

(51) INT CL⁶
H04B 10/14 10/24

(52) UK CL (Edition O)
H4B BK 14 BK24

(56) Documents Cited
GB 2264843 A US 5107404 A

(58) Field of Search
UK CL (Edition O) G2J JGED , H4B BK14 BK14C
BK14C2 BK14C2D BK14C4 BK14C4H BK14C4M BK14D
BK14D2 BK14D2B BK14D2C BK14D2D BK14D4
BK14D4B BK14D4C BK2 BK24 BK24R BK24S BK4 BK6 ,
H4L LECX , H4P PPC
INT CL⁶ G02B , H04B
Online: WPI, EDOC

(71) Applicant(s)
Methode Electronics Inc

(Incorporated in USA - Delaware)

7444 West Wilson Avenue, Chicago,
Illinois 60656-4549, United States of America

(74) Agent and/or Address for Service
Eric Potter Clarkson
St Mary's Court, St Mary's Gate, NOTTINGHAM,
NG1 1LE, United Kingdom

(72) Inventor(s)
Daniel S Poplawski
James W McGinley
Alan J Wallenberg

(54) Optical transceiver module

(57) The module is quick, easy, and inexpensive to manufacture. It has a main housing which consists of a potting box with potting material inserted therein and a circuit board encased by the potting material. The circuit board has the transceiver mounted on it. Access to the potting box is through a recess. A recess cover forms a liquid tight seal between the recess cover, the potting box, and the transceiver. The module housing is pluggable via release levers having detentes received in apertures of a receptacle and a pluggable connector of the module mated within the receptacle. The receptacle includes a grounding clip mounted within the receptacle which contacts a contact on the plug when it is inserted to prevent static electrical discharge into the electronic circuitry. It also has a protective door to limit electromagnetic emissions.

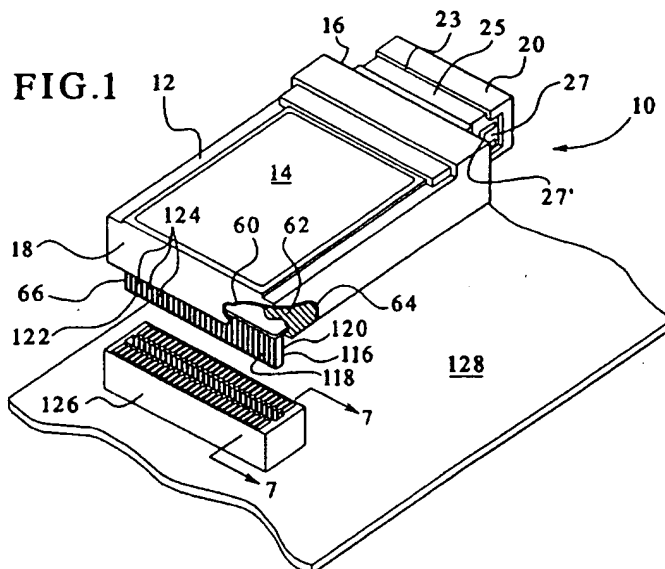

GB 2 297 007 A

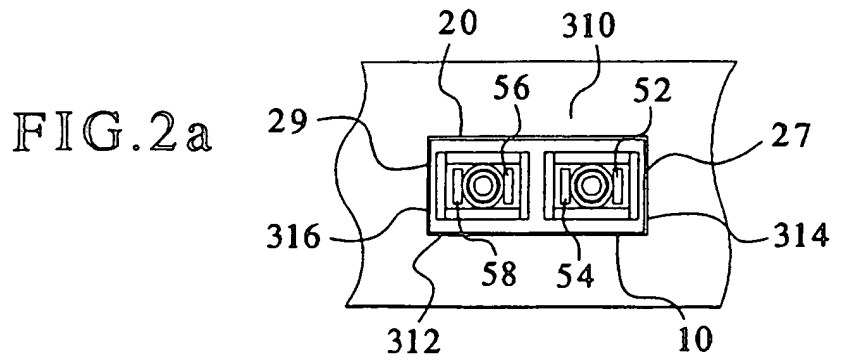
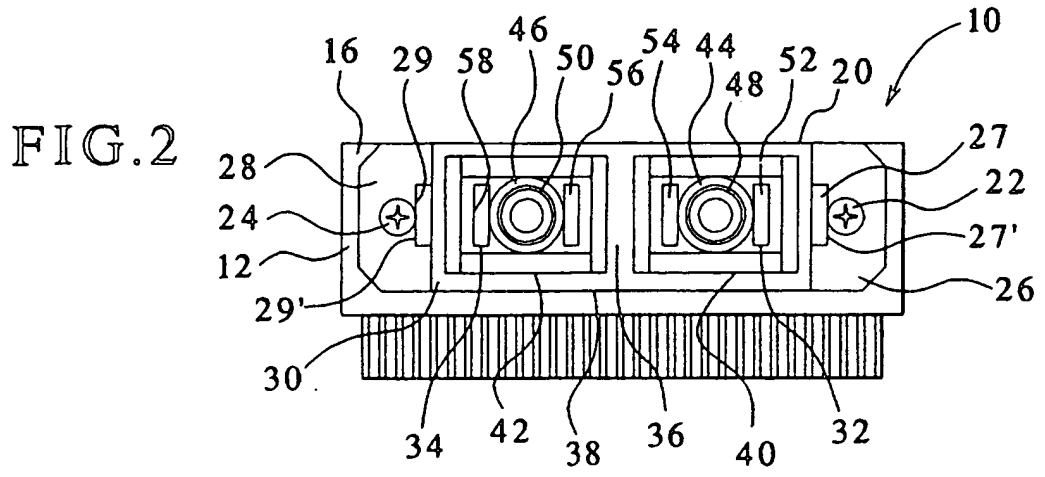
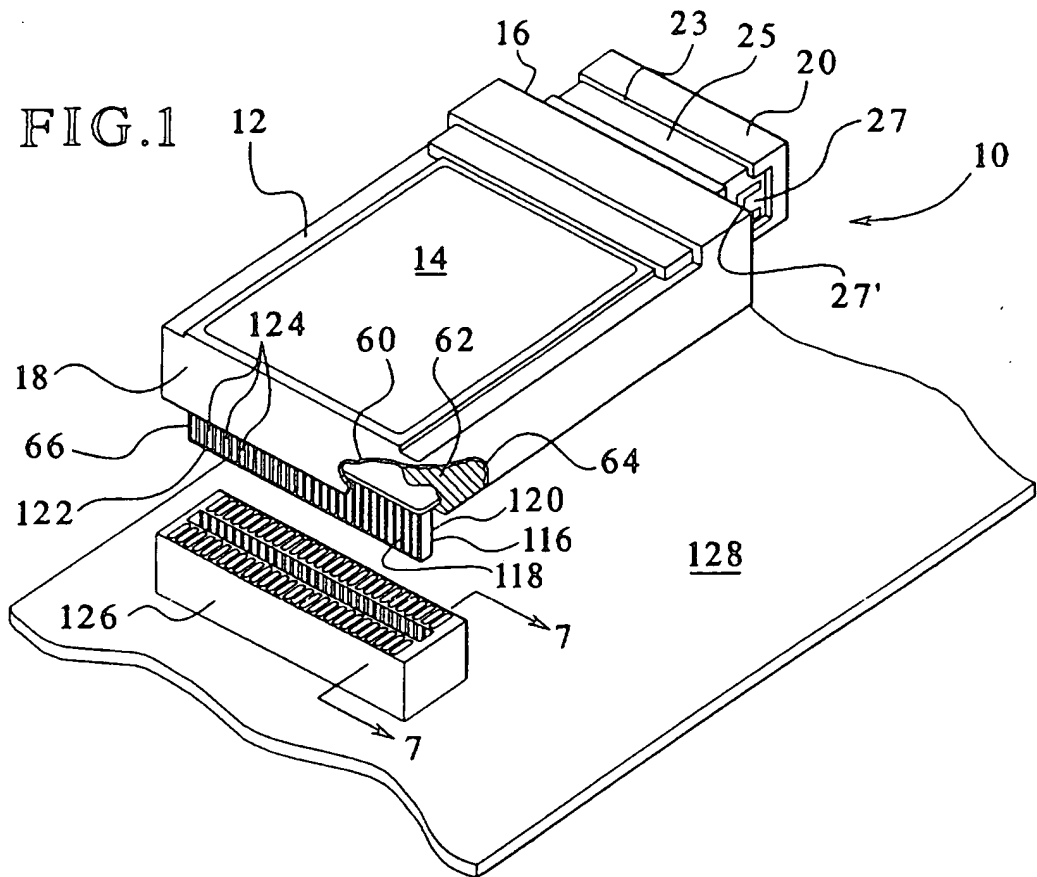

FIG. 3

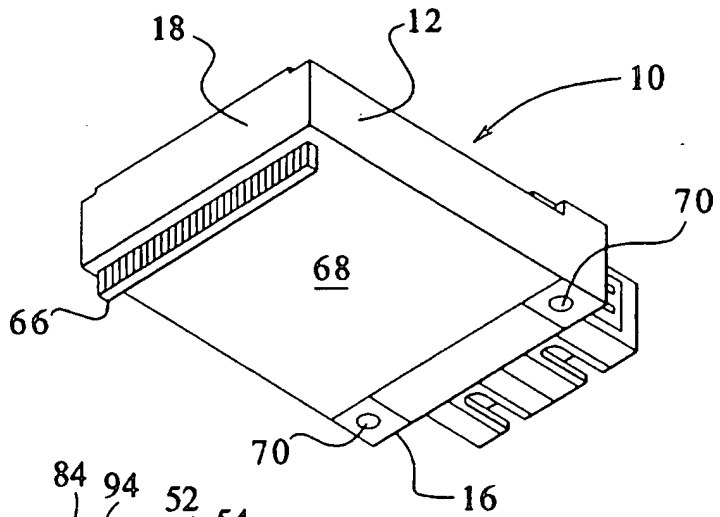

FIG. 4

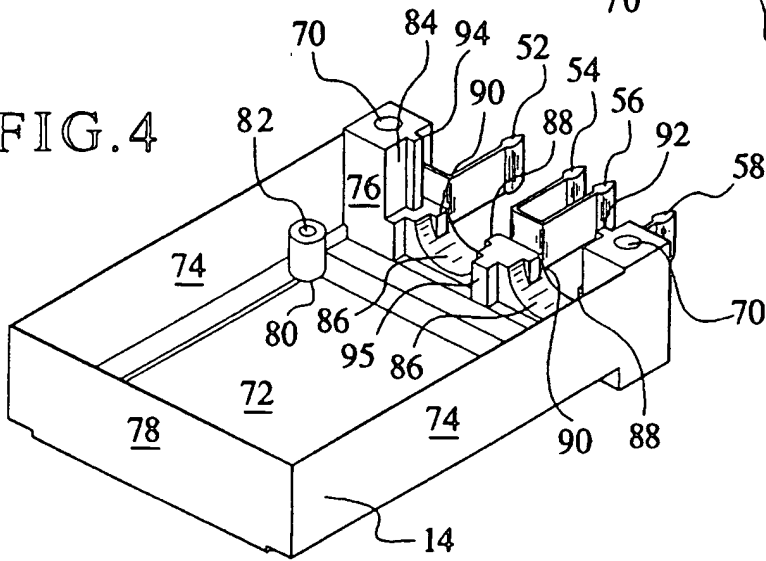

FIG. 5

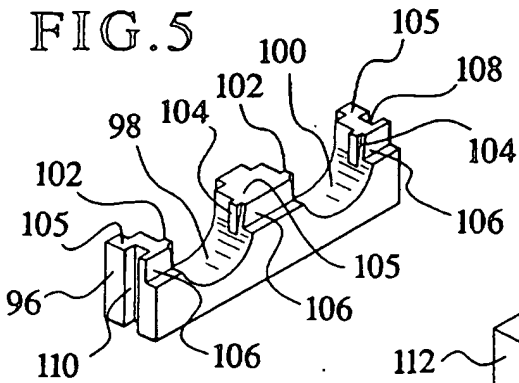

FIG. 6

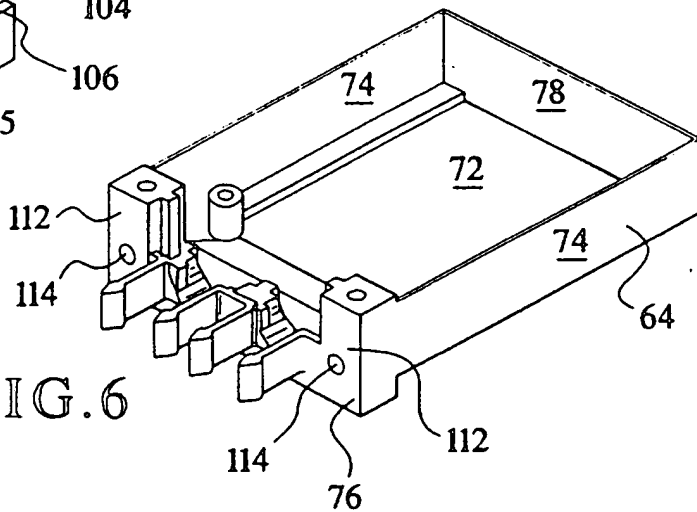

FIG. 7

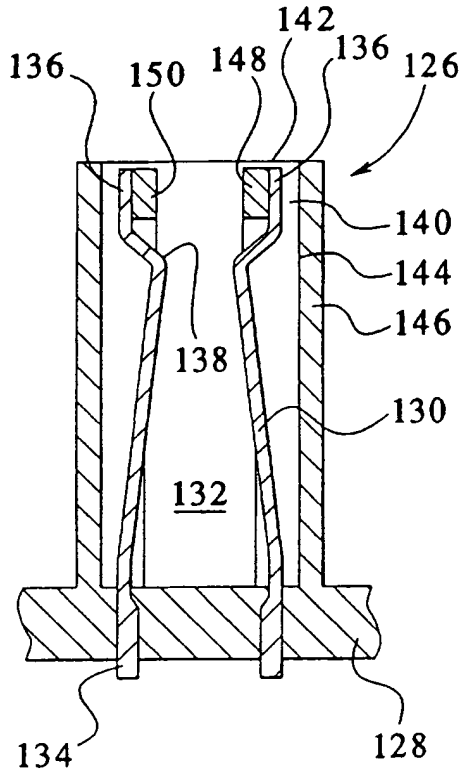

FIG. 9

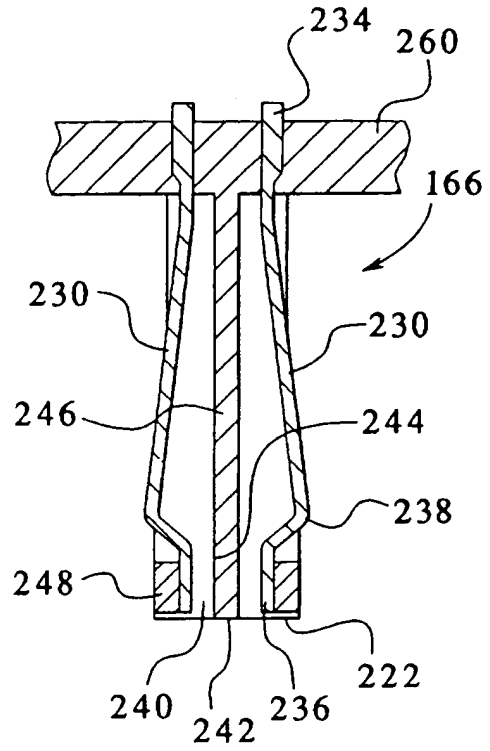
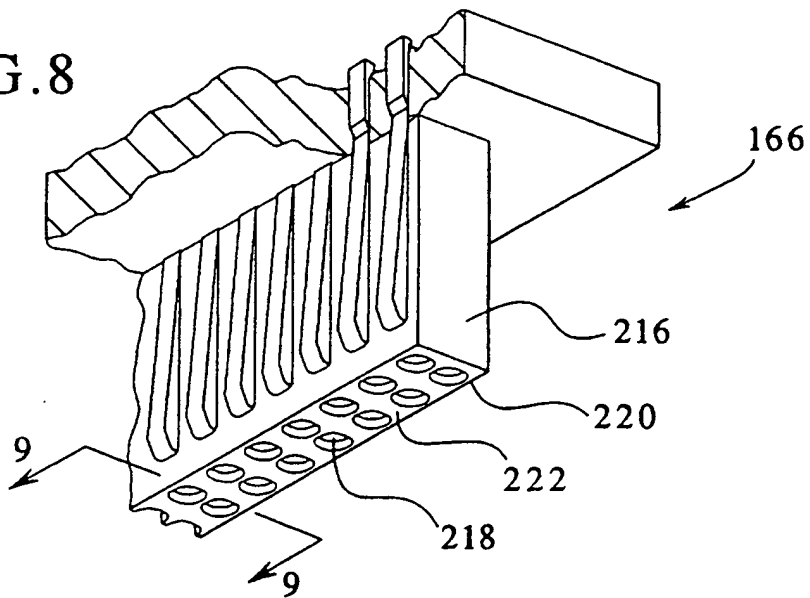

FIG. 8



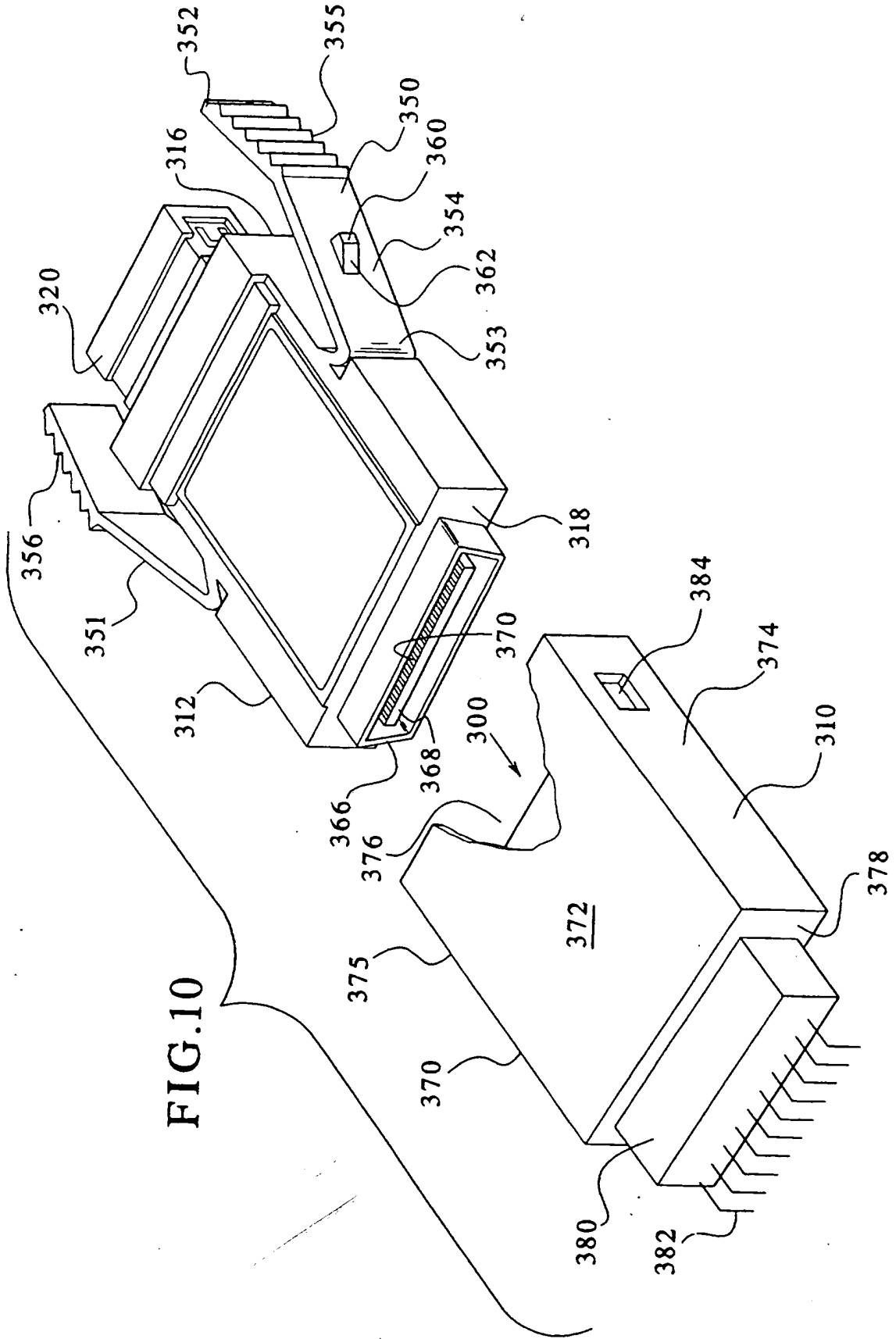

FIG.10

FIG. 11

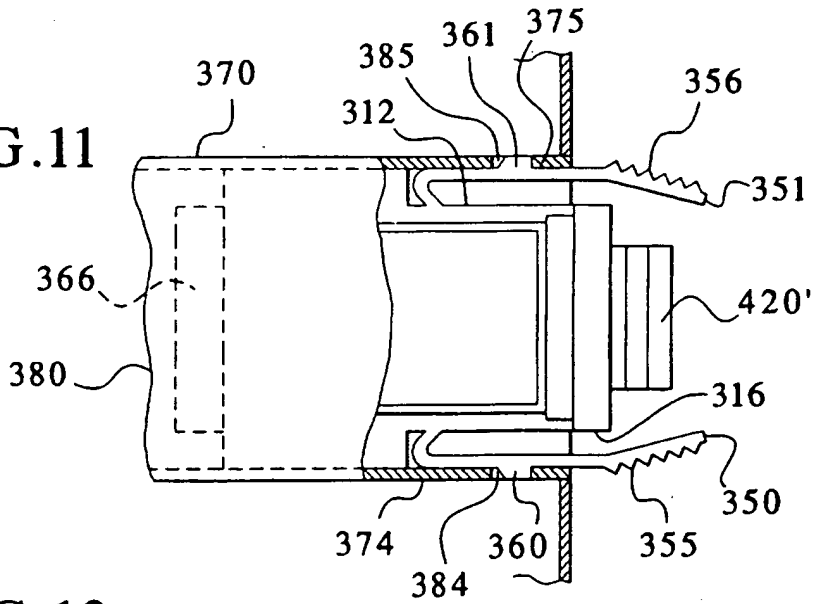

FIG. 12

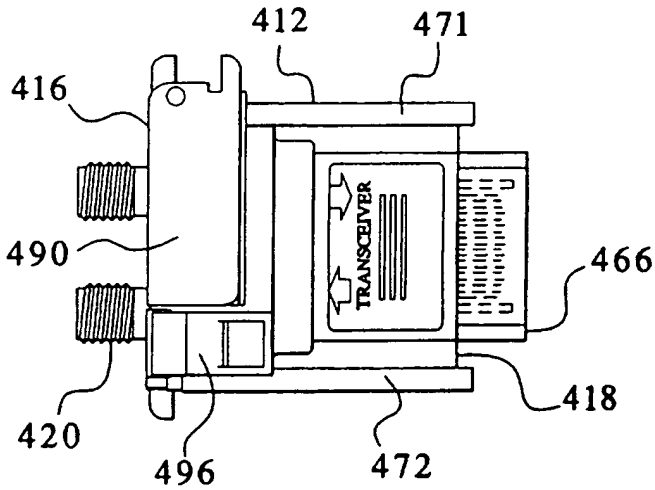

FIG. 13

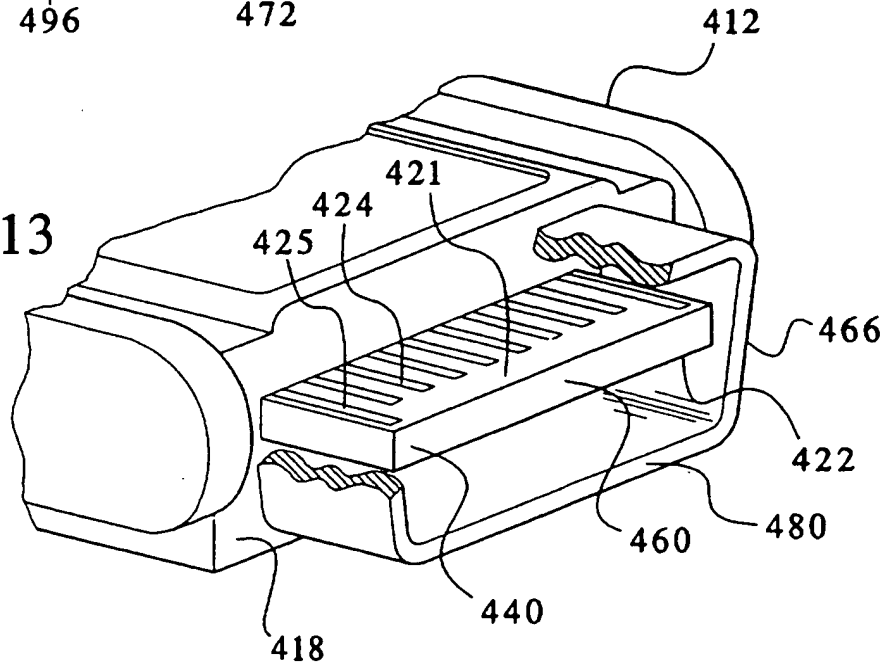

FIG.14

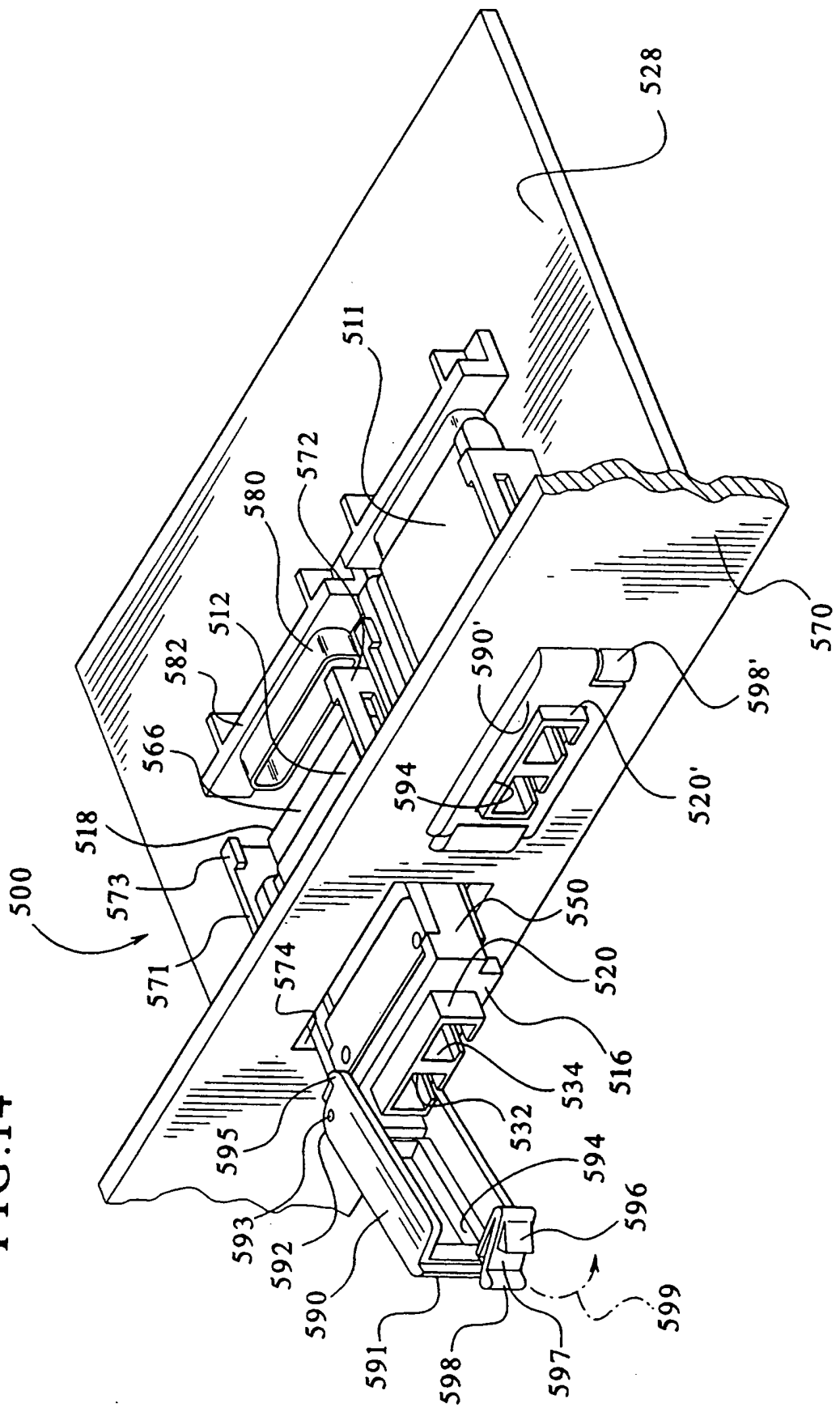

FIG. 15

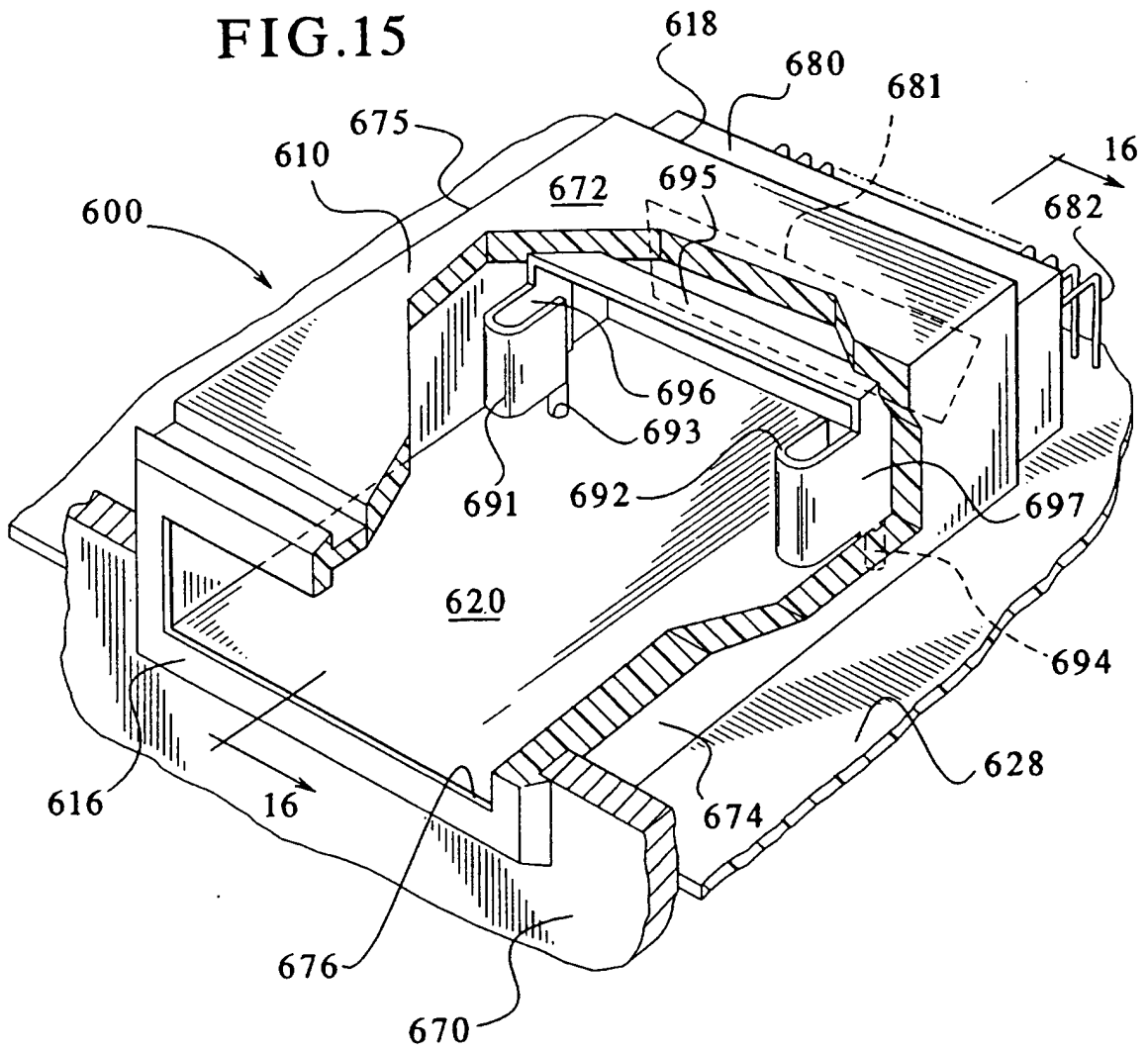

FIG. 16

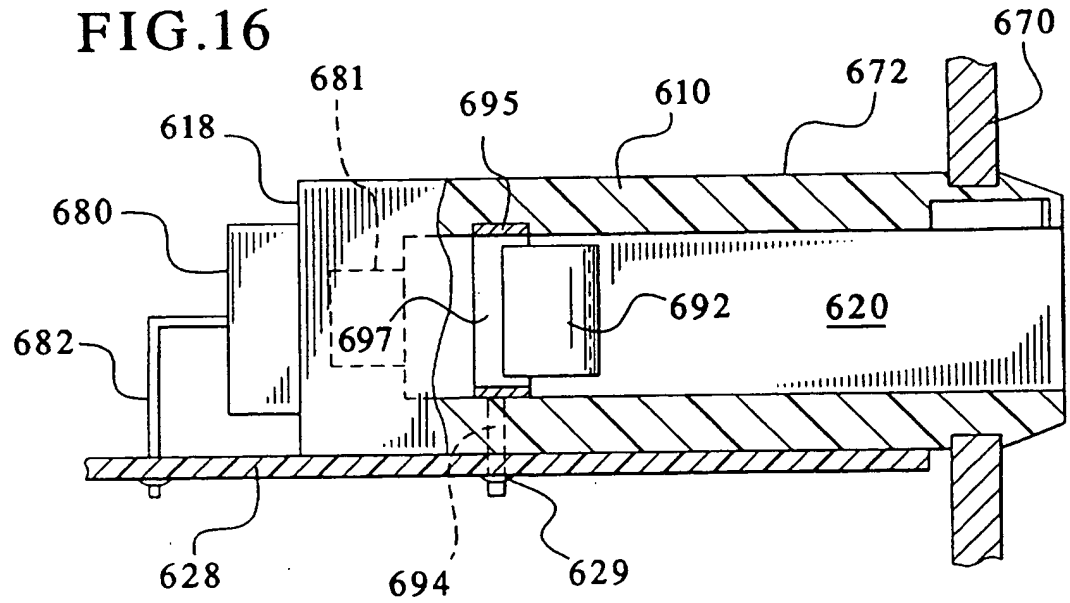

FIG.17

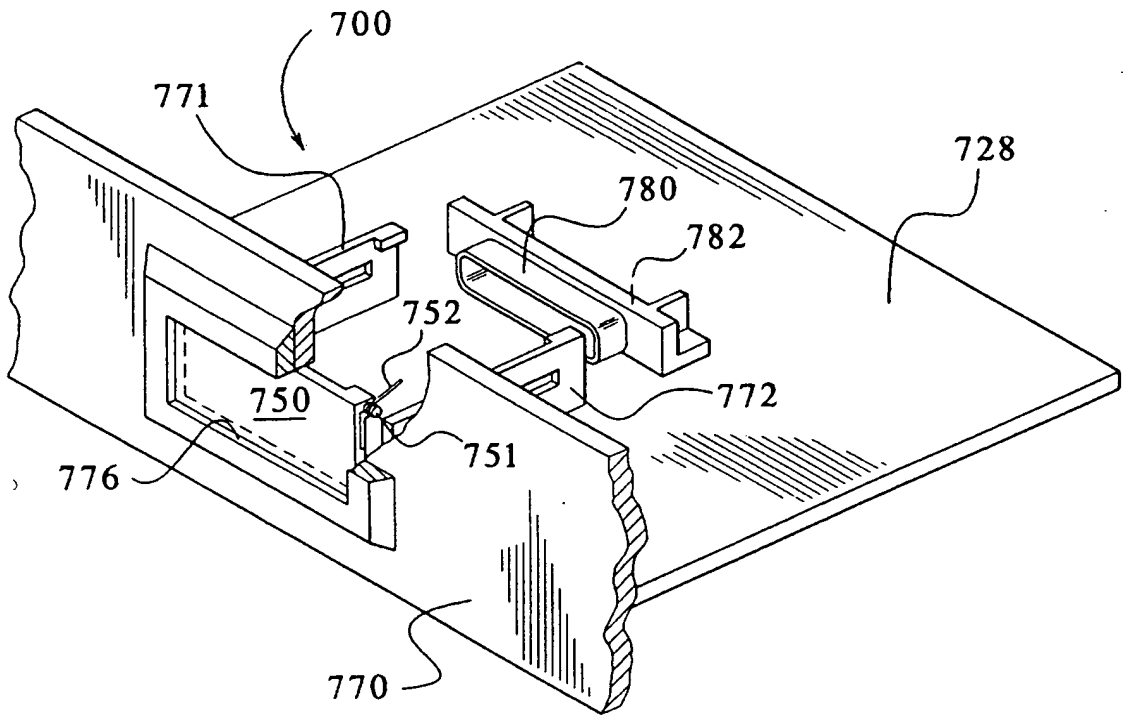
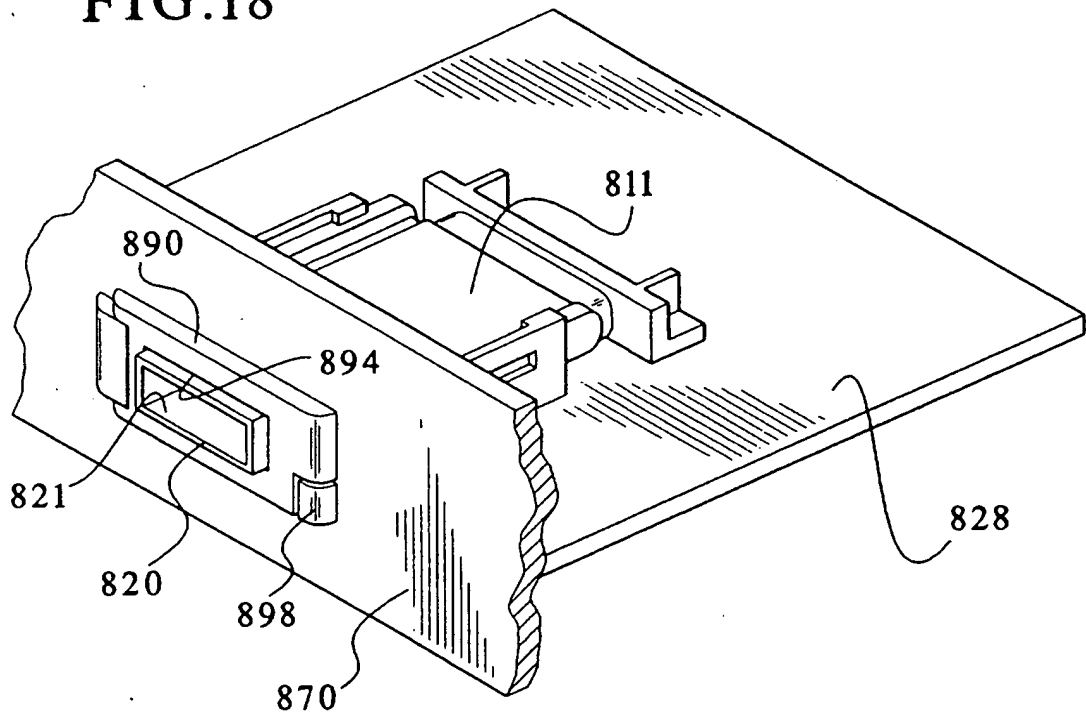

FIG.18



"REMOVABLE TRANSCEIVER MODULE AND RECEPTACLE"**Field of the Invention**

This invention relates generally to optoelectronic transceiver modules and in particular, it relates to an
5 optoelectronic transceiver module, and its method of
manufacture, whereby the module is inexpensive to
manufacture, has a small yet robust package, can be
installed and replaced via a ribbon style connector for
interchangeability and easy removal, provides for static
10 discharge, and can be installed and replaced via a ribbon
style connector.

Optoelectronic transceiver modules provide for the
bi-directional transmission of data between an electrical
interface and an optical data link. The module receives
15 electrically encoded data signals which are converted
into optical signals and transmitted over the optical
data link. Likewise, the module receives optically
encoded data signals which are converted into electrical
signals and transmitted onto the electrical interface.

20 Normally, the transceiver is mounted onto one of
the circuit card assemblies of a host computer,
input/output system, peripheral device, or switch.
Therefore, as with all electronic equipment, there is a
need for a transceiver having an outer package design
25 which occupies as little circuit card surface area as
possible.

In addition, there is a need for a transceiver
module which is highly reliable and durable. One method
presently used to ensure reliability and durability is
30 to encapsulate the electronics of the transceiver within
an insulative potting material. Encapsulating the

transceiver electronics results in reducing vibration sensitivity and prevents unauthorized personnel from meddling with the module's electronics.

5 Presently, the molding of the potting material around the transceiver electronics is performed by placing the electronics within a silicone mold. Any portion of the electronics which extends outside of the mold is caulked, by hand, with a silicone compound which provides for a liquid tight seal. Once the mold is
10 sealed, potting material is inserted therein. After the potting material is allowed to cure, the silicone mold is peeled away from the newly formed module.

The above described prior art molding process has several drawbacks. For example, it is time consuming and
15 results in a transceiver module which has a pitted outer surface. In addition, the silicone mold used in the molding process has a limited life of only three to five modules before a new mold must be employed.

The optoelectronic module is provided with a
20 plurality of electrical pins for forming an electrical connection with a circuit card assembly. The electrical pins consist of solid wire strands with each pin having one end connected to the electronics within the module and the other end protruding from the module's potting
25 material.

The portion of each pin which protrudes from the potting material is either soldered within a plated through-hole, which is provided by the circuit card assembly, or placed within a connector which grasps onto
30 the pin. However, the flimsy wire pins are very susceptible to deformation during both the normal handling of the module and its removal and installation onto a circuit card assembly. Thus, the flimsy pins

currently used in the prior art are difficult and time consuming to attach to a circuit card assembly since they must be periodically inspected and realigned. Furthermore, the pins may break if they are realigned too many times.

5 In addition to the electrical pins, the module also is equipped with two mounting ports for physically securing the module onto the circuit card assembly. The module is placed onto the circuit card assembly so that the mounting ports align with holes provided in the circuit card assembly. Once the module is properly aligned, screws are inserted through the holes in the circuit card assembly and into the mounting ports of the module. The screws are then tightened until the module is firmly affixed to the circuit card assembly.

10 Similarly, to remove the module from the circuit card assembly, the screws must be removed and the wires either unsoldered from the circuit card or pulled from the connector which is a timely and expensive process requiring multiple components. In fact, it is common for the entire circuit card assembly to be changed in order to change the transceiver module or the media interface.

15 Finally, once the module is secured to the circuit card assembly, optical fibers contained within an SC duplex plug connector are mated to the module. Normally, the SC duplex connector has a plastic housing which may be statically charged. Thus, its connection onto the transceiver module may result in damage to the electronic components within the module unless proper grounding of the SC connector is provided.

20 It should be appreciated by those skilled in the art that the possibility of damage due to static discharge is not only applicable to transceiver modules

which mate with an SC duplex connector. Other optoelectronic modules, such as, for example, Gigabaud Link Modules (GLM), are also susceptible to static discharge damage whenever they are mated to a connector
5 containing optical fibers.

Therefore, there is a need for a transceiver module which provides for a small, yet robust package, which is inexpensive to manufacture and can easily and quickly be installed and removed from a circuit card assembly in the
10 field provides for static discharge, and can easily and quickly be installed and removed from a circuit card assembly. The present invention is such an apparatus.

Likewise, there is a need for preventing a statically charged fiber optic connector from damaging
15 the electronics within an optoelectronic module.

In view of the above, it is an object of the present invention to provide a small transceiver module package.

It is another object of the present invention to
20 provide a module package that has a robust and tamper resistant design.

Also, it is an object of the present invention to provide a module which can quickly be installed and removed from a circuit card assembly.

25 Another object of the present invention is to provide a module package design that can quickly and easily be produced.

A further object of the present invention is to provide a module package that can be produced
30 inexpensively.

It is yet another object of the present invention to prevent a statically charged connector from damaging the electrical circuitry within an optoelectronic module

by pre-grounding the plug connector.

Furthermore, it is an object of the present invention to provide a module with a coating which dissipates an electrostatic discharge and serves as an electromagnetic shield.

As well, it is an object of the present invention to provide a module which is easily and quickly pluggable and removed to and from a housing.

Another object of the present invention is to provide a receptacle to receive the module having a grounding means.

It is also an object of the present invention to provide a receptacle having a means for preventing the escape of electromagnetic radiation from the receptacle.

Furthermore, it is an object of the present invention to provide an interchangeable transceiver module to provide electrical or fiber optic connection.

Summary Of The Invention

In one form of the invention, a robust optoelectronic transceiver module is provided which is quick, easy, and inexpensive to manufacture. The transceiver module has a main housing which consists of a potting box with potting material inserted therein. In addition, a circuit board is encased by the potting material.

The invention further provides for an optical subassembly to be mounted on a circuit board. In addition, the potting box has a recess which allows the optical subassembly to extend outside of the potting box. Furthermore, a recess cover may be provided for forming a liquid tight seal between the recess cover, the potting box, and the optical subassembly.

The optoelectronic transceiver module may also have

a ribbon style connector attached to the circuit board and protruding from the main housing. The ribbon style connector may protrude from either the bottom or one end of the main housing. In addition, the ribbon style connector may comprise of either a male ribbon style connector or a resilient male ribbon style connector.

5
10
In another form of the invention, an optoelectronic transceiver module is provided which mounts onto a circuit card assembly. The module has a main housing with a bottom. Protruding from the bottom of the main housing is a ribbon style connector which allows for quickly installing and replacing the module from the circuit card assembly.

15
20
In yet another form of the invention, a method of assembling an optoelectronic transceiver module is provided. The steps of the method consists of placing a circuit board within a potting box and injecting potting material within the potting box. In addition, the circuit board may be affixed within the potting box after the circuit board is positioned within the potting box. Furthermore, a liquid tight recess cover may be mounted within the potting box's recess after the circuit board is positioned within the potting box.

25
30
Also, the method of manufacture provides for coating the potting box with a conductive metal before the circuit board is placed within the potting box or after the potting material is injected within the potting box. Moreover, a connector shell may be mounted onto the potting box after the potting material is injected within the potting box.

In still another form of the invention, a method of assembling an optoelectronic transceiver is provided which includes the steps of affixing a circuit board

within a housing and securing a conductive metal coating onto the housing.

In another form of the invention, a potting box is provided for potting optoelectronic components which include an optical subassembly. The potting box includes a wall having a recess which allows the optical subassembly to extend outside of the potting box. In addition, a recess cover is provided for forming a liquid tight seal between the recess cover, the potting box, and the optical subassembly. Furthermore, the invention provides for the potting box to have a standoff column for mounting a circuit board within the potting box and an alignment guide for engaging a groove within the recess cover.

In still another form of the invention, a housing is provided including release levers having detentes which mate with an aperture of a receiving receptacle. The release lever includes a first end integrally molded to the housing and a second distal end protruding outward away from the housing having a gripping portion and intermediate the first end and the second end and intermediate portion having a detente protruding perpendicular from the surface of the intermediate section. The housing of the transceiver includes a first end and a second end. At the first end of the housing is a transceiver connector for receiving fiber optic plugs. At the second end of the housing is a pluggable connector.

In another form of the invention, a transceiver module and receptacle assembly is provided comprising a transceiver module housing having a first end and second end, a latching means attached adjacent the first end, a pluggable connector at the second end and a grounding

means associated with the receptacle. A receptacle housing is provided defining a chamber and the grounding means of the receptacle includes a ground tab protruding within the chamber. The ground tab is attached to an arm
5 which is molded within the receptacle housing. The receptacle housing has a first end having a protective door mounted thereto. The door is hinged adjacent the top surface of the receptacle housing. The transceiver module housing includes a metallized grounding portion to
10 come in contact with the grounding means of the transceiver receptacle in order to provide grounding of the transceiver module to the receptacle. The transceiver module external surface is metallized and upon insertion within the receptacle, the metallized
15 transceiver module housing abuts against a ground tab protruding within the receptacle chamber in order to ground the transceiver module to the receptacle. The latching means includes release levers attached to the sides of the transceiver module housing and latching to
20 the interior surface of the receptacle. A transceiver connector is attached to the first end of the transceiver module housing. The transceiver connector includes a fiber optic or electrical plug receptacle. The transceiver module includes an optoelectronic subassembly
25 for an optical media interface or electronic subassembly for an electrical media interface.

In still another form of the invention a transceiver module receptacle is provided comprising a receptacle housing having a first end and a second end,
30 a module receiving opening at the first end and an electrical connector at the second end. The first end includes a door hingedly attached at the first end. The door includes posts projecting from the edges for

mounting the door to the housing, Spring means are mounted to the posts of the door. The receptacle housing includes an inner chamber having walls defining the chamber. A ground surface protrudes from the walls for
5 contacting the grounding means of a transceiver module. The grounding surface is molded into the walls of the housing. The ground surface includes posts protruding through a bottom surface of the receptacle housing for mounting the receptacle to a motherboard.

10 In another form of the invention a transceiver module is provided comprising a transceiver module housing having a first end and a second end, a latching means attached adjacent the first end and a pluggable connector at the second end. The transceiver module
15 includes a transceiver connector at the first end.

The transceiver connector includes a modular port for receiving various media transducers. The media transducer includes a fiber optic plug receptacle and an optoelectronic subassembly or the media transducer
20 includes an electrical plug receptacle and an electrical subassembly. The pluggable connector includes a D-shaped shroud surrounding a circuit board protruding transversely from the second end and having electrical contacts attached thereto. The pluggable connector
25 includes ground contacts offset from adjacent electrical contacts.

In yet another form of the invention, an optoelectronic module is provided for mounting within a grounded structure, such as a computer chassis. The
30 optoelectronic module consists of electrically conductive latches which are conductively connected to a structure which provides for the forming of an electrical connection with the grounded structure. The

optoelectronic transceiver module may further include a transceiver connector attached thereto and which is conductively connected to the latches. Furthermore, a grounding clip may be attached to the transceiver connector. The grounding clip may have at least one tab extending therefrom. Accordingly, the optoelectronic module may use at least one tab for conductively connecting the latches to the grounded structure.

Additional features and advantages of the present invention are described in, and will be apparent from, the detailed description of the presently preferred embodiments and from the drawings.

These and other features of the invention are set forth below in the following detailed description of the presently preferred embodiments.

Brief Description of the Drawings

There is shown in the drawings a preferred embodiment of the present invention, wherein like numerals in the various figures pertain to like elements, and wherein:

FIG. 1 is an enlarged perspective view of an optoelectronic transceiver module in accordance with the present invention and having a partial fragmentary view depicting the module's circuit board and potting material;

FIG. 2 is a front view of the optoelectronic transceiver module depicted in FIG. 1;

FIG. 2a is a front view of a grounded computer chassis with the optoelectronic transceiver module of FIG. 2 extending through a connector port within the computer chassis.

FIG. 3 is a bottom perspective view of the optoelectronic transceiver module depicted in FIG. 1;

FIG. 4 is an enlarged perspective view of the potting box used in the manufacture of the optoelectronic module depicted in FIGS. 1-3;

5 FIG. 5 is a perspective view of the recess cover used with the potting box of FIG. 4;

FIG. 6 is another enlarged perspective view of the potting box of FIG. 4;

10 FIG. 7 is an enlarged cut-away side view of the female ribbon style connector taken along line 7-7 of FIG. 1;

FIG. 8 is an enlarged perspective view, along with a partial fragmentary view, of a resilient male ribbon style connector for use with the optoelectronic transceiver module of FIGS. 1-3;

15 FIG. 9 is a cut-away side view of the resilient male ribbon style connector taken along line 9-9 of FIG. 8;

FIG. 10 is a plan view of the alternative embodiment shown in FIG. 10 but in a mated orientation;

20 FIG. 11 is a plan view of an alternative embodiment of a transceiver module having an electrical interface of the present invention;

Fig. 12 is an enlarged perspective view of an end of the transceiver module of Fig. 12;

25 FIG. 13 is a perspective view of an alternative embodiment of a transceiver module of the present invention mounted to a receptacle assembly;

FIG. 14 is a perspective, partially cut-away view of a receptacle of the present invention;

30 FIG. 15 is a side elevation cut-away view of FIG. 15 taken at line 16-16;

FIG. 16 is a perspective view of an alternative embodiment of a receptacle assembly; and

FIG. 17 is a perspective view of another alternative embodiment of a receptacle assembly of the present invention; and

5 FIG. 18 is a perspective view of an alternative embodiment of the present invention shown in an unmated orientation.

Detailed Description of the Presently Preferred Embodiments

Referring to the drawings, and particularly to FIG. 10 1, an enlarged perspective view of an optoelectronic transceiver module 10 in accordance with the present invention is depicted. The module 10 has a main housing 12 which generally has the shape of an oblong box. The main housing 12 has a generally rectangular top 14 with 15 a first end 16 and an opposite second end 18 extending perpendicularly from the top. Attached to the first end 16 of the main housing 12 is a transceiver connector 20 for receiving fiber optic plugs.

Turning to FIG. 2, a front view of the 20 optoelectronic transceiver module 10 is depicted. The transceiver connector 20 is attached to the first end 16 of the main housing 12 by two screws 22,24. The two screws 22,24 extend through the transceiver connector's mounting ears 26,28 and into the main housing 12. 25 Extending perpendicularly from the mounting ears 26,28 is a generally rectangularly shaped connector shell 30. The connector shell 30 provides two receptacles 32,34 for receiving fiber optic connector plugs. The receptacles 32,34 are formed by the connector shell 30 along with a 30 divider wall 36 which extends along the center of the connector shell. Furthermore, located in the bottom 38 of each receptacle 32,34 is a keying channel 40,42 which extends toward the first end 16 of the main housing.

In the preferred embodiment, the receptacles 32,34 of the connector shell 30 are specifically dimensioned to receive an SC duplex plug. Therefore, the keying channels 40,42 ensure that an SC plug will be inserted so that receptacle 32 will only accept a plug for sending data and receptacle 34 will only accept a plug for receiving data.

Extending from the main housing 12 and into each of the receptacles 32,34 is an optical subassembly 44,46. As previously indicated, the optical subassembly 44 is for sending transmissions over a data link and the optical subassembly 46 is for receiving transmissions over a data link. In order to facilitate the connection between the transceiver 10 and the data links, each optical subassembly has a ferrule receiving portion 48,50. The ferrule receiving portion 48,50 couples with the SC plug. Furthermore, the transceiver's latch members 52,54,56, and 58 firmly hold the SC plug in contact with connector 20.

The actual sending and receiving of optically encoded data is performed by a laser diode within the optical subassembly 44 and a photo diode within the optical subassembly 46. Both the laser diode and the photo diode are electrically connected to a circuit board which is mounted within the main housing 12.

Turning back to FIG. 1, a portion of the circuit board 60 is depicted. Incorporated onto the circuit board 60 is circuitry for transmitting and receiving optically encoded data (circuitry not shown). The circuit board 60 is encased in potting material 62 and a potting box 64 which forms the main housing 12. The potting material 62 encases the circuit board 60 such that only the circuit board's male ribbon style connector

66 extends from the potting material 62.

Turning to FIG. 3, a perspective view of the bottom 68 of the transceiver module 10 is depicted. In the preferred embodiment, the bottom 68 has two mounting ports 70,70 which are adjacent to the first end 16 of the main housing 12. In addition, the male ribbon style connector 66 protrudes perpendicularly from the bottom 68 and is adjacent to the second end 18 of the main housing 12.

In an alternative embodiment, the ribbon style connector 66 may protrude perpendicularly from the second end 18 of the module 10 so that it can be connected to a circuit card assembly in a direction which is parallel to the direction of insertion of the optic plugs into the module's receptacles. However, in this alternative embodiment, another recess cover will be needed in order to prevent potting material from escaping the second end of the potting box.

Referring to FIG. 4, an enlarged perspective view of the optoelectronic module's potting box 64 is depicted. The potting box 64 forms the outer housing of the optoelectronic module. Thus, the potting box generally has the shape of an oblong box with a rectangular bottom 72, two parallel side walls 74,74, a first end wall 76, and an opposite second end wall 78. In a preferred embodiment, the potting box 64 is injection molded of a polymer material such as VALOX, STANYL, or any other glass-filled heat resistant material which can withstand solder reflow temperatures. The use of such a potting box eliminates the need for a silicone mold required by prior art modules.

In addition, it is preferred that the potting box 64, including the latch members 52,54,56, and 58, be

either plated, wet plated, or vacuum metalized with an aluminum or stainless steel coating in order to dissipate an electrostatic discharge and provide for electromagnetic shielding. As well, the transceiver connector 20 (FIG. 1) may be either plated, wet plated, or vacuum metalized, in order to reduce emissions and enhance grounding of the module. Such metalization of the connector 20 can bring the module in compliance with FCC Rules, Part 15. In a preferred embodiment, the connector 20 is metalized separately from the potting box 64 so that each attachment portion is metalized and provides for conductivity between the parts. As the connector 20 will be attached to a chassis containing fiber optic connectors which are at ground potential, the connector will ground the metalized potting box 64 which is attached to a daughter board. Such grounding enhances the module's ability to dissipate electrostatic discharge and provide for electromagnetic shielding. The transceiver connector 20 also includes a grounding clip 25 attached at the slot 23.

As also shown in FIGS. 1-3, the transceiver connector 20 includes a grounding clip 25 attached at the slot 23 in the connector 20. The grounding clip 25 serves as a means for forming an electrical connection with an externally grounded structure such as a computer chassis. Correspondingly, the grounding clip 25 is made of a metallic material, such as stainless steel, and includes two tabs 27,29 which protrude from each side of the connector 20. The tabs 27,29 are generally rectangular in shape with only one side of each tab being united to the grounding clip 25. Correspondingly, each tab 27,29 has a respective distal end 27',29' which extends away from the connector 20. In a preferred

embodiment, the connector 20 is first metalized and then the ground clip 25 is attached so that an electrical conductive path is maintained between the grounding clip 25 and the connector 20.

5 Moving to FIG. 2a, a front view of the outside of a grounded computer chassis 310 is depicted with the connector 20 of the optoelectronic transceiver module 10 extending through a connector port 312 within the computer chassis. As commonly known in the art, the
10 computer chassis 310 is typically made of a conductive metallic material and is tied to a ground potential (i.e., grounded) by conventional means. Furthermore, the chassis provides a connector port 312 for each
15 optoelectronic transceiver module mounted within the computer chassis (only one connector port and one transceiver module is depicted in FIG. 2a). The connector port 312 consists of an opening which is dimensioned so that the transceiver module connector 20
20 can extend through the connector port. Therefore, the transceiver module 10 can be mounted within the chassis 310 of a computer with the transceiver module connector 20 extending from, and being readily accessible from, the outside of the computer chassis.

Correspondingly, when the transceiver module
25 connector 20 is positioned within the connector port 312, the tabs 27,29 will press against the sides 314,316 of the connector port. Consequently, the tabs 27,29 will form an electrical connection with the computer chassis which will result in the transceiver module connector 20
30 becoming grounded. In addition, the entire metalized potting box, including the metalized latch members 52,54,56, and 58, will become grounded since, as indicated previously, the transceiver module connector

20 is conductively attached to the potting box.

Correspondingly, a means of pre-grounding an SC connector is provided by the grounded latch members 52,54,56, and 58. For example, as an SC connector is
5 attached to the transceiver module 10, the housing of the SC connector will first abut against one of the ground latch members 52,54,56, and/or 58. Accordingly, any static charge on the SC connector will be removed by the grounded latched members via the conductive electrical
10 path from the potting box, to the transceiver connector, its corresponding grounding clip, and then to the grounded computer chassis via the tabs 27.

As previously indicated, all of the transceiver's latch members 52, 54, 56, and 58 extend from the first
15 wall 76 of the potting box 64. Also, the first end wall 76 of the potting box furnishes the mounting ports 70,70 which are located on the bottom of the main housing. In a preferred embodiment, the latch members 52, 54, 56 and 58 are integrally molded with the potting box 64.

20 Circuit board standoff columns 80 are also provided by the potting box 64 (only one standoff column is depicted in FIG. 4). Each standoff column protrudes from the bottom 72 of the potting box 64 and is positioned next to the first end wall 76 and one of the side walls
25 74,74 for supporting the circuit board 60. The standoff columns 80 have a length equal to approximately half the depth of the potting box 64 with the distal end of the column having a circuit board mounting port 82.

30 As depicted in FIG. 4, the first wall 76 of the potting box 64 has a recess 84 for allowing the placement of the circuit board's optical subassemblies. The recess 84 has two semicircular through-ports 86,86. Within each through-port 86,86 are two guide beams 88,90 which are

positioned on each end of the through-port's semicircle for positioning the optical subassemblies 44,46.

Also located on the first wall 74 are two recess cover alignment guide beams 92,94. The alignment guide
5 beams 92,94 border each side of the recess 84 and extend along the entire depth of the recess. The bottom of the recess 84 has three flat mating surfaces 95 (only two of the mating surfaces are depicted in FIG. 4).

Correspondingly, referring to FIG. 5, a recess
10 cover 96 is depicted for placement within the recess located in the first wall of the potting box. Preferably, the recess cover 96 is made of the same material as the potting box and is either plated, wet plated, or vacuum metalized with an aluminum or stainless
15 steel coating.

In FIG. 5, the recess cover 96 has two semicircular through-ports 98,100. Within each of the through-ports 98,100 are two guide beams 102,104 positioned on each end of the through-port's semicircle. Also, the top of the
20 recess cover includes three flat mating surfaces 105.

The recess cover 96 firmly mounts within the recess of the potting box's first wall so that the mating surfaces 95 and 105 of both the recess 84 and the recess cover 96 will abut each other. The recess cover 96
25 includes three indentions 106 which allow the cover to be positioned around the location where the latch members 52, 54, 56, and 58 attach to the potting box. In addition, on each end of the recess cover 96 there are alignment grooves 108,110 which provide for sliding
30 engagement with the alignment guide beams 92,94 bordering the recess within the potting box's first wall.

Referring back to FIG. 4, during the manufacture of the transceiver module the circuit board is placed in

the potting box 64 with the male ribbon connector protruding outside of the potting box and the circuit board's optical subassemblies protruding out of the recess 84 in the first wall 76. The optical subassemblies 44,46 are properly positioned within the potting box 64 by the alignment guides 88,90 located within each through-port 86,86.

Once positioned within the potting box 64, the circuit board 60 is affixed by two screws which are mounted to the standoff columns 80 via the circuit board mounting ports 82.

Once the circuit board 60 is secured within the potting box 64, the recess cover 96 is mounted onto the first end wall 76. The recess cover 96 is mounted by engaging its alignment grooves 108,110 with the potting box's recess cover alignment guide beams 92,94. When the recess cover 96 is slid into position, the cover's through-ports 98,100 and associated alignment guide beams 102,104 will adjoin the circuit board's optical subassemblies 44,46. Furthermore, due to the tight tolerances of both the potting box 64 and the recess cover 96, a liquid tight seal will be formed between the potting box 64, the recess cover 96, and the optical subassemblies 44,46. Thus, with the recess cover 96 in place, potting material is injected within the potting box 64 for encasing the circuit board 60. The time to mold the module by the above method is reduced by approximately 90% over the prior art molding process because no hand caulking is needed to form the liquid tight seal.

Finally, referring to FIG. 6, the connector shell (See FIG. 1 & 2) is mounted onto the first end wall 76 of the potting box 64 after the potting material has

cured. Alignment of the connector shell 20 is provided by two mounting posts 112,112. Each mounting post 112 has a bore 114 which facilitates the attachment of the connector shell 20, by the use of the previously mentioned screws, onto the potting box 64.

In an alternative embodiment, the ribbon style connector 66 may protrude perpendicularly from the second end 18 of the module 10 so that it can be connected to a circuit card assembly in a direction which is parallel to the direction of insertion of the optic plugs into the module's receptacles. However, in this alternative embodiment, another recess cover will be needed in order to prevent potting material from escaping the second end of the potting box.

Referring back to FIG. 1, the male ribbon style connector 66 protruding from the module 10 has a beam portion 116, made of insulative material, which extends perpendicularly across the length of the circuit board 60. The male ribbon style connector 66 also has a first side 118, an opposite second side 120, and a distal end 122. Extending perpendicularly from the circuit board 60 on both the first side 118 and the second side 120 of the male ribbon style connector 66 are twenty-eight electrical contacts 124. Each electrical contact 124 consists of a strip of conductive material which is affixed to the male ribbon style connector 66 and is electrically connected to the circuitry mounted on the circuit board 60.

Correspondingly, the male ribbon style connector 66 couples to a female ribbon style connector 126 which is mounted onto the circuit card assembly 128. Referring to FIG. 7, an enlarged cut-away side view is shown of the female ribbon style connector 126 taken along line 7-7

of FIG. 1. The female ribbon style connector 126 has two parallel rows of twenty-eight (28) contact beams 130,130 contained within a contact chamber 132 (only one contact from each row is depicted). Each contact beam 130 is
5 constructed of a flat strip of conductive metallic material. Furthermore, each contact beam 130 has a first end 134, a second distal end 136, and a bend 138 which is located adjacent to the second end and extends toward the contact beam located in the opposite row.

10 The female ribbon style connector 126 is mounted onto the circuit card 128 such that the first end 134 of each contact beam 130 extends through the circuit card assembly. Likewise, the second end 136 of each contact beam 130 extends within a travel limitation slot 140
15 formed in the top 142 of the female ribbon style connector 126. Each slot 140 provides a backstop 144, consisting of one of the connector's walls 146, and a frontstop 148. Correspondingly, contact beams 130,130 are positioned in the chamber 132 such that the second
20 end 136 of each contact beam 130 resiliently urges against the frontstop 148.

In order to provide access to the contact beams 130,130 within the female ribbon style connector 126, the top 142 of the connector has a slot 150 positioned
25 between the two rows of contact beams. Correspondingly, in order to make an electrical connection between the female ribbon style connector 126 and the male ribbon style connector 166 depicted in FIG. 1, the distal end 122 of the male ribbon style connector is inserted within
30 the female connector's slot 150. As the male ribbon style connector 66 is pushed further within the female connector's chamber 132 the two rows of contact beams 130 will be forced to separate further from each other. In

addition, each contact beam 130 will resiliently urge against a corresponding electrical contact 124 mounted on the male ribbon style connector 66. Thus, an electrical connection will be formed between the male ribbon style connector's electrical contacts 124,124 and the female connector's contact beams 130,130.

Similarly, to disconnect the male ribbon style connector's electrical contacts 124,124 from the female connector's contact beams 130,130 the male connector 66 is simply pulled from the chamber 132 of the female connector. Once the male ribbon style connector 66 has been removed from the chamber 132, the contact beams 130 of the female connector 126 will resiliently regain the configuration of FIG. 7, whereby the second end 136 of each contact beam will abut its corresponding frontstop 148.

Turning to FIG. 8, an enlarged perspective view, along with a partial fragmentary view, is depicted of a resilient male ribbon style connector 166. The connector 166 includes a beam type housing 216 having a first side 218, an opposite second side 220, and a distal end 222. The resilient male ribbon style connector 166 in FIG. 8 serves as another embodiment of the male ribbon style connector depicted in FIGS. 1-3 wherein the male connector in FIG 8 is resilient and the male connector in FIG. 1-3 is non-resilient. It should be noted, however, that other means for quickly installing and replacing the module from a circuit card assembly may be used.

Referring to FIG. 9, an enlarged cut-away side view of the resilient male ribbon style connector 166 is shown taken along line 9-9 of FIG. 8. The male ribbon style connector 166 has two parallel rows of twenty-

eight (28) contact beams 230, (only one contact from each row is depicted). Each contact beam 230 is constructed of a flat strip of conductive metallic material. Furthermore, each contact beam 230 has a first end 234,
5 a second distal end 236, and a bend 238 which is located adjacent to the second end and extends away from the contact beam located in the opposite row.

The male ribbon style connector 166 is mounted onto the module's circuit board 260 such that the first end
10 234 of each contact beam 230 extends through the circuit board. In a preferred embodiment, the first end 234 of the contact 230 is inserted within a through-hole of the circuit board 260 which contains traces for providing an electrical connection from the contact 260 to components
15 mounted on the board. Likewise, the second end 236 of each contact beam 230 extends within a travel limitation slot 240 formed in the top 242 of the resilient male ribbon style connector 166. Each slot 240 provides a backstop 244, consisting of the connector's support
20 wall 246, and a frontstop 248. Corresponding, contact beams 230,230 are positioned such that the second end 236 of each contact beam 230 resiliently urges against the frontstop 248.

Access for making an electrical connection with the
25 contact beams 230,230 is provided since they protrude from the male ribbon style connector 166 in the area around the bends 238,238. Correspondingly, in order to make an electrical connection between a female ribbon style connector and the resilient male ribbon style
30 connector 166, the distal end 222 of the male ribbon style connector is inserted within a slot provided by the female connector. As the male ribbon style connector 166 is pushed within the female connector, the two rows of

contact beams 230,230 will be forced to compress towards each other. In addition, each contact beam 230 will resiliently urge against a corresponding electrical contact mounted within the female ribbon style connector. Thus, an electrical connection will be formed between the male ribbon style connector's electrical contact beams 230,230 and the female connector's contact beams.

Similarly, to disconnect the resilient male ribbon style connector 166 from the female connector, the male connector is simply pulled from the female connector. Once the male ribbon style connector 166 has been removed, the contact beams 230,230 will resiliently regain the configuration of FIG. 9, whereby the second end 236 of each contact beam will abut its corresponding frontstop 248.

An alternative embodiment of the present invention is shown in FIG. 10 having a main housing 312, having a first end 316 and a second end 318. As discussed in the previous embodiments, the housing 312 includes optical subassemblies for sending transmission over a data link and receiving transmissions over a data link. The preferred embodiment is an optoelectronic transceiver, however, a simplex transmitter or receiver or multiple transmitters or receivers may be incorporated in the module housing of the alternative embodiment. At the first end 316 is a transceiver connector 320 for receiving fiber optic plugs. In an alternative embodiment, optical fibers may be directly attached to the module and the optical subassemblies therein. At the second end 318 is a pluggable connector 366. In the preferred embodiment, the pluggable connector 366 is a D-shaped connector having a printed circuit board 368 having multiple contact traces 370 adhered thereto. The

transceiver housing 312 is pluggable into receptacle 310 and is inserted into the receptacle 310 in direction of arrow 300. The receptacle 310 includes a receptacle housing 370 having a top 372 and sides 374,375. The
5 receptacle housing 370 includes an open end 376 and a closed end 378. At the closed end 378 of the receptacle housing 370 is a connector 380 for mating with the pluggable connector 366. The connector 380 protrudes into the interior the receptacle housing 370 and has an
10 aperture for receiving the pluggable connector 366 of the transceiver housing 312. In the preferred embodiment, the connector 380 is a female connector for receiving the male connector 366. However in an alternative
15 embodiment, the pluggable connector 366 of the transceiver housing 312 may be a female connector and the connector 380 of the receptacle housing 370 would be a male connector. Protruding from the connector 380 are contacts 382 for direct connecting to a printed circuit board in a peripheral device such as a work station or
20 computer to wire the connector 380 directly to traces of a printed circuit board. In an alternative embodiment, a flat ribbon cable for transmitting the electrical signals protrudes from the transceiver module. The receptacle housing 370 includes in sides 374,375
25 aperture 384 for providing the locking of the transceiver within the receptacle housing 370.

The transceiver housing 312 includes a pair of release levers 350,351. The description of release lever 350 is the same of that for 351. The release
30 lever 350 includes a first end 353 which is attached to the side of the transceiver housing 312. In a preferred embodiment, the release lever 350 is integrally molded with the transceiver housing 312. The release lever 350

includes a second end 352 which includes a gripping portion 355 which has lined edges to assist in gripping of the release lever 350. Intermediate to the first end 353 and the second end 352 is an intermediate portion 354. The intermediate portion 354 angles outwardly away from the sides of the transceiver housing 312. Attached at the end of the intermediate portion 354 is the second end 352 which is generally parallel to the side of the transceiver housing 312. However, as the intermediate portion 354 angles outward and away from the side of the transceiver housing 312, the second end 352 is at a distance from the sides of the transceiver housing 312 in its nonmated condition. Protruding from the intermediate portion 354 is detente 360. The detente 360 includes an engagement surface 362. Upon insertion of the transceiver housing 312 into the receptacle 370, the intermediate portion 354 abuts against the side 374 of the receptacle housing 370 and causes the release lever 350 to compress inwardly toward the housing 312. As the housing 312 is further inserted within the receptacle, the engaging portion 362 abuts against the sidewall 374 of the receptacle housing 370 causing the release lever 350 to compress further. Upon further insertion, the detente 360 engages aperture 384 of the receptacle housing 370 and the release lever 350 snaps outwardly to engage the aperture 384. Upon snapping outwardly of the release lever 350, the transceiver housing 312 is fully mated within the receptacle housing 370. In this fully mated position, the pluggable connector 366 is fully mated with the connector 380 of the receptacle housing 370.

For removal of the transceiver housing 312 from the

receptacle housing 370, the release levers 350,351 are grasped at the gripping portion 355 of the second end 352 in order to compress the levers inwardly toward the transceiver housing 312. The compression of the release
5 levers 350 releases the detente 360 from the aperture 384 of the receptacle housing 370. Allowing the pluggable connector 366 of the transceiver housing 312 to be removed from the connector 380 of the receptacle housing and for the entire transceiver housing 312 to be removed
10 from the receptacle 370.

Turning to FIG. 11, a top view of the alternative embodiment of the transceiver of the present invention is shown mated within a receptacle. The transceiver housing 312 is mated within receptacle housing 370. The
15 release levers 350,351 are compressed within the sidewalls 374,375 of the receptacle housing 370. The detentes 360,361 of the release levers 350,351, respectively, are seated within the apertures 384,385. In the fully mated position, the pluggable connector 366
20 is mated with the connector 380 of the receptacle housing 370. It can be seen that in order to release the transceiver housing 312 from the receptacle 370, the gripping portions 355,356 of the release levers 350,351 are protruding from the receptacle housing 370 and may
25 be grasped between two fingers and compressed together in order to release the detentes 360,361 from the apertures 384,385 and to then release the transceiver from the receptacle.

Still referring to FIG. 11, transceiver
30 connector 420' is shown attached to the first end 316 of the transceiver module housing 312. In this alternative embodiment, the transceiver connector 420' may have an electrical connection and receive electrical plugs. As

an alternative to the transceiver connector 320 shown in FIG. 10 which was described to receive fiber optic plugs, the transceiver connector 420' of FIG. 11 may receive electrical plugs. For example, a copper wired electrical connector may be inserted in the transceiver connector 420 having a receptacle opening for receiving the electrical plug therein (see also FIG. 12). In the alternative embodiment, the copper transceiver module housing 312 will not have optical subassemblies mounted therein. However, an electrical subassembly for the transceiver described above is still contained within the transceiver module, such as a transformer or other AC coupling means and differential (balanced) or single ended (unbalanced) transmission line drive and receive circuits. By providing a transceiver module 312 which supports different types of media in a common housing design, the transceiver module may be easily upgradable in the field. For example, an initial installation of an optical transceiver module (as shown in FIG. 12) having multi-mode capabilities could provide transmission distances of approximately 500 meters. Should the system be reconfigured so that the required transmission distances decrease to 20 to 30 meters, the multi-mode optical transceiver could easily be replaced with a less costly copper transceiver (as shown in FIG. 11) using the removable housing of the present invention. Such an operation can be easily accomplished by a technician in the field due to the easily disengageable latching means 350 and the pluggable connector 366 of the transceiver housing 312 and other features of the present invention discussed herein. Additionally, further upgrades may be accomplished in later reconfigurations that may require transmission distances of up to 10 kilometers by

replacing the transceiver module with an optical transceiver module of the present invention having single-mode capabilities.

5 Referring to FIG. 12 a copper transceiver as discussed above is disclosed. The transceiver module housing 412 includes first end 416 and second end 418. Running between the first and second end along the sides of the transceiver housing 412 are rails 471, 472 for mounting to the guide rails of the receptacle assembly as disclosed in FIG. 14. The second end 418 of the transceiver housing is inserted into a receptacle assembly, such as shown in FIGS. 14-17, and pluggable connector 466 provides electrical connection to the receptacle assembly and a motherboard. The first end 416 includes a latch cover 490 to latch the transceiver housing 412 to the receptacle assembly, as discussed in more detail below. The latch cover 490 also includes latch member 496. Mounted at the first end 416 are a pair of transceiver connectors 420. In the embodiment of FIG. 12 the transceiver connectors are copper connectors for receiving electrical coaxial cable such as an SMA connector.

15 Turning to FIG. 13, an enlarged perspective view of the second end 418 of the transceiver housing 412 is disclosed. The pluggable connector 466 or male ribbon style connector includes a D-shaped shroud 480 encircling an insulative substrate 460 such as a circuit board. The circuit board 460 protruding from the transceiver housing 412 has a first side 421, an opposite second side 422, and a distal end 440. Extending perpendicularly from the second end 418 of the transceiver housing 412 is circuit board 460 having affixed on both the first side 421 and the second side 422 twenty electrical contacts 424. Each

electrical contact 424 consists of a strip of conductive material which is affixed to circuit board 460 and is electrically connected to the circuitry mounted on the circuit board 460 within the transceiver module 412. The first side 421 of the circuit board 460 includes ten electrical contacts 424 affixed thereto. As shown in FIG. 13 the electrical contacts are numbered 1 through 10. The first and tenth contact adjacent the side edges of the circuit board 460 are ground contacts 425. The ground contacts 425 extend out to the distal end 440 of the circuit board 460. The remaining contacts, two through nine, are off-set from the distal end 440 of the circuit board 460. This arrangement of the ground contacts 425 protruding further than the electrical contacts 424 allows for the hot plugging of the transceiver module 412 to a receptacle assembly which is already operational and powered up. The ground contacts 425 will make electrical contact with the receptacle assembly prior to the electrical contacts 424, allowing the transceiver module to reach the ground potential of the receptacle assembly before the electrical contacts 424 are connected to the receptacle assembly. This arrangement provides a common ground in order to dissipate static discharge to ground potential prior in sequence to connection of other electrical contacts 424. The second side 422 of the circuit board 460 may also have an arrangement similar to the first side 421 of the circuit board 460 in order to provide grounding for hot plugging.

Turning to FIG. 14, a further alternative embodiment of the present invention is shown. In the further alternative embodiment, pluggable transceiver housings 511,512 provide for a pluggable transceiver.

However, the pluggable transceiver housings 511,512 have an alternative embodiment to the release levers 350,351 as shown in FIGS. 10 and 11. The transceiver housings 511,512 include a cover latch 590,590' as an alternative means for latching the transceiver housings to a receptacle assembly 500. FIG. 14 shows transceiver housing 512 partially mounted to a receptacle assembly 500. Transceiver housing 511 is shown fully mated to the receptacle assembly 500. The receptacle assembly 500 includes a motherboard or circuit card assembly 528, a mounting panel 570 adjacent and perpendicular to a front side and attached to the motherboard 528, mounting rails 571,572 and a circuit card connector 580 attached to connector bracket 582 which is mounted to the motherboard 528. These elements of the receptacle assembly 500 may also define a housing of a device such as a host computer, server or PC. The elements described relating to the transceiver housing 512 are also included for the transceiver housing 511, but will not be separately identified in order to avoid redundancy.

Transceiver housing 512 includes a first end 516 having a transceiver connector 520 attached thereto. In a preferred embodiment, the transceiver connector 520 receives optical plugs such as a duplex SC fiber optic connector. However, in an alternative embodiment, as discussed above, the transceiver connector 520 may provide an electrical connection by receiving an electrical plug having copper wires. However, in the case where the transceiver connector 520 receives fiber optic plugs, the receptacle openings 532,534 have mounted therein latches for receiving the fiber optic plug and adjacent thereto an optical subassembly mounted within

the transceiver housing 512 (see FIG. 2). The transceiver connector 520 is mounted to a transceiver housing frame 550. In a preferred embodiment, the transceiver connector 520 and the transceiver frame 550 are integrally molded of a polymer material. The transceiver frame 550 may also form a potting box as discussed above. Mounted at a second end 518 of the transceiver housing 512 is a pluggable connector 566. In a preferred embodiment, the connector 566 is a D-shaped connector as discussed above (FIG. 13). The pluggable connector 566 being oriented at the second end 518, opposite the first end 516 of the transceiver housing 512, allows for the quick and easy insertion of the transceiver housing 512 into the receptacle assembly 500 and for pluggably mating the transceiver housing 512 to the circuit card connector 580 of the receptacle assembly 500 all in a single motion. The transceiver housing frame 550 is received by guide rails 571,572. The guide rails 571,572 include detentes 573 for guiding the transceiver housing frame 550 and maintaining the transceiver housing 512 in a parallel orientation to the motherboard 528 and for aligning the pluggable connector 566 to the circuit card connector 580.

Upon insertion of the transceiver housing 512 within the receptacle assembly 500, approximately three quarters of the way, the latch cover 590 securedly mounts the transceiver housing 512 to the receptacle assembly 500. The latch cover 590 includes a first side 591 and a second side 592. The second side 592 of the latch cover 590 is hingedly attached to the first end 516 of the transceiver housing 512. An attachment means 593 attaches the latch cover 590 so that it swings

in a transverse direction to the first end 516 of the transceiver housing 512 in direction of arrow 599. The second side 592 of the latch cover 590 also includes a boss 595. Upon insertion of the transceiver housing 512 into the receptacle assembly 500 and initial rotation of the latch cover in direction of arrow 599, the boss 595 will catch on the mounting panel opening 574. The boss 595 engages the backside of the mounting panel 570 and pushes the transceiver housing 512 toward its completely mated orientation within the receptacle assembly 500. As the latch cover 590 is rotated in direction of arrow 599, it is moved into an orientation so that it is almost parallel with the front surface of the mounting panel so that latch member 596 engages the opening 574 of the mounting panel 570. The latch member 596 is attached to resilient beam 597 attached to the first side 591 of the latch cover 590. Upon engagement of the latch member 596 with the opening 574, the resilient beam 597 is compressed toward the first end 591 of the latch cover 590. The latch cover 590 is then moved to its fully latched position and the resilient beam 592 springs outwardly so that the latch member 596 engages the back of the mounting panel 570. The latch member 596 may be released from its latched position by depressing the release lever 598 attached at the end of the resilient beam 597. In a preferred embodiment, the latch cover 590, latch member 596, resilient beam 597 and release lever 598 are integrally molded of a polymer material.

In an embodiment of the transceiver housing 512, the latch cover 590 may be metallized and the mounting panel 570 also metallized or made of a metallic material and grounded, so that attachment of the transceiver

housing 511,512 to the mounting panel 570 via the metallized latch cover 590 automatically grounds the transceiver housings 511,512.

Turning to the transceiver housing 511 shown fully
5 mated with the receptacle assembly 500 in FIG. 14, the
latch cover 590' is shown fully latched to the mounting
panel 570 so that the front surface of the latch
cover 590' is parallel to the front plane of the mounting
panel 570. The latch cover 590' includes window 594 from
10 which the transceiver connector 520 protrudes. Upon
fully mounting of the transceiver housing 511 within the
receptacle assembly 500 and the complete latching of the
cover latch 590', plugs may be inserted into the
transceiver connector 520'. In many circumstances, the
15 transceiver housing 511 can remain within the receptacle
assembly 500 for a long period of time and in some cases,
the transceiver housing 511 may never need to be replaced
or removed. However, in certain circumstances, the
transceiver housing 511 may need updating or repair. The
20 present design allows for the easy removal and
reinsertion of the transceiver housing 511. For example,
the transceiver housing 511 may need to be modified so
that a different media interface transceiver
connector 520' may be utilized and added to the housing.
25 Or in another instance, the functioning of the
transceiver module may need to be updated by adding a new
chip set or optoelectronic subassembly. By depressing
the release lever 598' the latch cover 590' may be
unlatched and rotated to an "open" position. Once the
30 latch cover 590' is "open," the latch cover 590 may be
gripped and used as a handle to aid in pulling the
transceiver housing 511 from the receptacle assembly 500.
Once removed, the transceiver module housing 511 may then

be repaired, replaced or updated.

Turning to FIGS. 15-16, a further alternative embodiment of the present invention is shown. Generally, FIGS. 15-16 show a new and improved receptacle for receiving a transceiver module, such as those described herein. For example, the receptacle 310 disclosed in FIG. 10 is more clearly illustrated by reference to FIGS. 15-16. Similarly, the receptacle shown in FIGS. 15-16 is configured to receive the transceiver housing 312 shown in FIGS. 10-11. A receptacle assembly 600 is shown in FIG. 15 having a motherboard 628 and a mounting panel 670 having mounted thereto a transceiver receptacle 610. The receptacle 610 has a first end 616 having an opening 676 and a second end 618 having a connector 680 adjacent thereto. The transceiver receptacle 610 also includes top 672 and sides 674, 675.

The walls of the receptacle 610 define a chamber 620. FIG. 15 is partially cut-away to expose the chamber 620 within the receptacle 610. Mounted within the chamber 620 are ground surfaces or tabs 691, 692. The ground tabs 691, 692 protrude into the chamber 620 and are oriented to abuttingly engage or wipe against the external surfaces of a transceiver module mounted within the receptacle 610. The outer surfaces of a transceiver housing are metallized so that upon insertion within the chamber 620 and engagement with the ground tabs 691, 692, the transceiver module will be grounded. The ground tabs 691, 692 include ground posts 693, 694. The ground posts 693, 694 are mounted in and grounded to the motherboard 628. The ground tabs 691, 692 are joined by brace 695. The ground tabs 691, 692 are attached to the brace 695 via arms 696, 697. The arms 696, 697 and the brace 695 in a preferred embodiment are insert molded

within the receptacle housing 610. The insert molding is controlled so that only the ground tabs 691,692 protrude into the chamber 620 and the ground posts 693,694 protrude out from the bottom of the receptacle 610.

5 The receptacle connector 680 includes contacts 682 which are attached to the motherboard 628. Protruding into the chamber 620 from the connector 680 is receptacle connector 681 for receiving the D-shaped connector at the end of the transceiver module inserted within the
10 receptacle 610. (See FIG. 10.)

Turning to FIG. 16, a side elevation cut-away view of FIG. 15 taken at line 16-16 is shown. The receptacle housing 610 is shown mounted to the motherboard 628 and
15 the mounting panel 670. Ground clip 692 protrudes into the chamber 620 and grounds the metallized transceiver housing to the motherboard 628. The ground tab 692 is attached to arm 697. Protruding from the arm 697 is ground post 694 which is mounted within the plated
20 through hole of motherboard 628 and is secured to the motherboard with solder 629 and provides for grounding to the motherboard. At least a portion of the arm 697 and a portion of the ground post 694 and brace 695 are molded within the polymer material of the receptacle
25 housing 610. Receptacle connector 680 is attached at the second end 618 of the receptacle 610. Attached to the receptacle connector 680 is D-shaped receptacle 681 and contacts 682.

Turning to FIG. 17 an alternative embodiment is
30 provided where the receptacle assembly 700 includes a circuit card assembly or mother board 728, a mounting panel 770, mounting rails 771, 772 and a circuit card connector 780 attached to connector bracket 782. Mounted

to the mounting panel 770 is a protective door 750. The mounting panel 770 is partially broken away to more clearly show the door 750. The door 750 is hinged at a point at the top of the door 750. Post 751 protrudes from the edge of the door and is received by an aperture in the mounting panel 770. Mounted on the post 751 is a resilient member 752 such as a spring. The spring 752 is configured in order to return the door 750 to its closed position parallel to the front face of the mounting panel 770 after the door 750 has been opened. The protective door 750 acts as a shield in order to limit electromagnetic radiation from escaping from the receptacle assembly 700 when the receptacle assembly 700 is empty. Certain power sources and components mounted to the motherboard 728 may develop electromagnetic emissions. In absence of a door such as 750 upon removal of a transceiver module from the receptacle assembly 700, the electromagnetic emissions generated by the components mounted on the motherboard 728 would be free to escape through the opening 776. Attachment of the protective door 750 to the mounting panel inhibits these emissions. The protective door 750 may be metal or metallized in order to further reduce such emissions. Also by incorporation of door 750 to the receptacle assembly 700 the receptacle may be left empty upon initial construction of the receptacle assembly 700, allowing for assembly of multiple receptacle assemblies 700 on motherboard 728 for reception of additional transceiver modules at a later date. The post 751 provides for a hinge to the door 750 and allows for the swinging motion of the door. The door 750 is hinged so that upon abutment of a transceiver module against the door and attempted insertion of the transceiver module through

opening 776, the door will swing inwardly allowing the transceiver module to be inserted therein. While the transceiver module is housed within the receptacle assembly 700 the door 750 will remain in an upright position adjacent the top of the transceiver module. Upon removal of the transceiver module from the receptacle assembly 700, the spring 752 causes the door 750 to swing back to its closed position parallel to the front face of the mounting panel 770.

Turning to FIG. 18, another alternative embodiment of the present invention is shown. Attached to the transceiver housing 811 is a transceiver connector 820 which is an alternative embodiment of the transceiver connector 520 of transceiver housing 512 of FIG. 14. The transceiver connector 820 is shown having a modular port 821. The modular port 821 is configured so that any number of receptacle connectors may be inserted therein for receiving various types of plugs. Due to the easily removable nature of the transceiver module 811, the transceiver can be removed so that a plug receptacle (not shown) mounted within the modular port 821 may be removed and disconnected from the components within the transceiver module 811 and a new plug receptacle inserted within the modular port 821 and connected to the components of the transceiver module 811. Such an operation is best accomplished by the manufacturer using this orientation to achieve quick assembly and just-in-time manufacture and to avoid remolding of the entire module housing. The transceiver module 811 can then be easily reinserted and attached to the receptacle assembly 800. For example, the transceiver module 811 may be configured for transmitting and receiving electrical signals from an external device having an

electrical plug inserted into the transceiver connector 820, as discussed above. Such a copper plug would be inserted into a copper plug receptacle which is mounted within the modular port 821. For example, a DB-9
5 connector may be used. In another embodiment, an alternative fiber optic receptacle could be inserted within the modular port 821. For example, a multiple channel connector such as an MT connector could be attached to the transceiver housing 811 by inserting an
10 updated optical fiber receptacle within the modular port 821 of the transceiver connector 820 to receive a multi-channel connector.

In another embodiment, a media transducer may be inserted within modular port 821. The media transducer
15 may include at a first end a connector receptacle such as coaxial connector 420 of FIG. 12 or an SC duplex connector 520 of FIG. 12. A second end of the media transducer may include an optoelectronic subassembly such as a PIN diode, laser diode such as LED and other optical
20 circuitry for optical media; or an electrical subassembly such as a transformer or other AC coupling means for copper media. In another embodiment, the media transducer may include only a connector receptacle or only an optoelectronic or electronic subassembly. Such
25 a media transducer would allow for the updating or changing of the media interface by removing the media transducer from the modular port 820 and replacing with another media transducer.

It should be understood that in describing the top
30 and bottom portions of the transceiver module and its respective potting box components, the terms "top" and "bottom" are used by way of example only due to the orientation of the drawings. It should also be

understood that various changes and modifications to the presently preferred embodiments described herein will be apparent to those skilled in the art. Furthermore, although the transceiver module depicted in the presently preferred embodiment has its male ribbon style connector extending from the bottom, it should be understood from the outset that the connector can be configured to extend, for example, from the second end of the transceiver. Therefore, changes and modifications may be made without departing from the spirit and scope of the present invention and without diminishing its attendant advantages. Thus, it is intended that such changes and modifications be covered by the appended claims.

PATENT CLAIMS:

1. A transceiver module and receptacle assembly comprising:

5 a transceiver module housing having a first end and second end;

a latching means attached adjacent the first end and a pluggable connector at the second end; and

a grounding means associated with the receptacle.

10 2. The transceiver module and receptacle assembly of Claim 1 including:

a receptacle housing defining a chamber; and

the grounding means of the receptacle includes a ground surface protruding within the chamber.

15 3. The transceiver module and receptacle assembly of Claim 2 wherein the ground surface is attached to an arm which is molded within the receptacle housing.

4. The transceiver module and receptacle assembly of Claim 1 including:

20 a receptacle housing having a first end having a protective door mounted thereto.

5. The module and receptacle system of Claim 4 wherein the door is hinged adjacent the top surface of the receptacle housing.

25 6. The transceiver module and receptacle assembly of Claim 1 including:

30 the transceiver module housing having a metallized grounding portion to come in contact with the grounding means of the transceiver receptacle in order to provide grounding of the transceiver module to the receptacle.

7. The transceiver module and receptacle

assembly of Claim 6 wherein the transceiver module external surface is metallized and upon insertion within the receptacle, the metallized transceiver module housing abuts against a ground surface protruding within the
5 receptacle chamber in order to ground the transceiver module to the receptacle.

8. The transceiver module and receptacle assembly of Claim 1 wherein the latching means includes release levers attached to the sides of the transceiver
10 module housing and latching to the interior surface of the receptacle.

9. The transceiver module and receptacle assembly of Claim 1 including a transceiver connector attached to the first end of the transceiver module
15 housing.

10. The transceiver module and receptacle assembly of Claim 9 wherein the transceiver connector is a fiber optic plug receptacle.

11. The transceiver module and receptacle assembly of Claim 10 wherein the transceiver module
20 includes an optoelectronic subassembly.

12. The transceiver module and receptacle of Claim 9 wherein the transceiver connector is an electrical plug receptacle.

25 13. The transceiver module of Claim 12 wherein the transceiver module includes an electrical subassembly.

14. An optoelectronic transceiver module for mounting within a grounded structure, said optoelectronic
30 transceiver module comprising:

- a) a main housing comprising a metalized potting box and potting material contained within said potting box;

- b) metalized latches conductively extending from said potting box; and
- c) means for forming an electrical connection between said metalized latches and said grounded structure.

5

15. The optoelectronic transceiver module of Claim 14 further comprising:

a transceiver connector attached to said potting box.

10

16. The optoelectronic transceiver module of Claim 15 further comprising:

a grounding clip attached to said transceiver connector.

15

17. The optoelectronic transceiver module of Claim 16 further comprising:

at least one tab extending from said grounding clip.

20

18. The optoelectronic transceiver module of Claim 14, wherein said electrical connection forming means consists of at least one tab conductively connected to said potting box.

25

19. The optoelectronic transceiver module of Claim 18, wherein said electrical connection forming means further consists of a grounding clip having said tab extending therefrom and being conductively connected to said potting box.

30

20. A system for providing static discharge or electromagnetic shielding, said system comprising:

a metallic chassis at ground potential; and
a transceiver module mounted to said chassis having a grounding clip connected to said chassis and a connector receptacle having electrically conductive latches wherein upon mating of a plug to said connector

receptacle an electrical path from said connector to said chassis provides for a pre-grounded plug.



Application No: GB 9525323.3
Claims searched: all

Examiner: Dr E P Plummer
Date of search: 26 February 1996

Patents Act 1977
Search Report under Section 17

Databases searched:

UK Patent Office collections, including GB, EP, WO & US patent specifications, in:

UK Cl (Ed.O): H4B(BK2,BK4,BK6,BK14,BK14C,BK14C2,BK14C2D,BK14C4,
BK14C4H,BK14C4M,BK14D,BK14D2,BK14D2B,BK14D2C,BK14D2D,
BK14D4,BK14D4B,BK14D4C,BK24,BK24R,BK24S); G2J(JGED);
H4L(LECX); H4P(PPC)

Int Cl (Ed.6): H04B; G02B

Other: Online:- WPI, EDOC

Documents considered to be relevant:

Category	Identity of document and relevant passage	Relevant to claims
A	GB2264843A TEXAS INSTRUMENTS nb connections 1,4,6,11,14 of plug 254 (figure 7) which are earthed. & US5321819, EP0567342A	
A	US5107404 ASTEC INTERNATIONAL LTD eg abstract	

X	Document indicating lack of novelty or inventive step	A	Document indicating technological background and/or state of the art.
Y	Document indicating lack of inventive step if combined with one or more other documents of same category.	P	Document published on or after the declared priority date but before the filing date of this invention.
&	Member of the same patent family	E	Patent document published on or after, but with priority date earlier than, the filing date of this application.